



UNIVERSITY COLLEGE TATI (UC TATI)

FINAL EXAMINATION QUESTION BOOKLET

COURSE CODE	: BET 2023
COURSE	: DIGITAL SYSTEM
SEMESTER/SESSION	: 1-2023/2024
DURATION	: 3 HOURS

Instructions:

1. This booklet contains **4** questions. Answer **ALL** questions.
2. All answers should be written in answer booklet.
3. Write legibly and draw sketches wherever required.
4. If in doubt, raise up your hands and ask the invigilator.

DO NOT OPEN THIS BOOKLET UNTIL YOU ARE TOLD TO DO SO

THIS BOOKLET CONTAINS 8 PRINTED PAGES INCLUDING COVER PAGE

QUESTION 1

- a) Signal carrying information can be divided into two broad categories which are digital and analog. Answer the followings question.
- Define analog and digital signal. (2 marks)
 - Draw the waveform of analog and digital signal. (2 marks)
- b) List **TWO (2)** types of number system used in digital signal. (2 marks)
- c) Convert the following number systems to hexadecimal number. Write your answers up to two decimal places and shows the working method.
- 198.33_{10} (4 marks)
 - 1001010.11001_2 (4 marks)
- d) Convert 147.3_{10} to binary coded decimal (BCD) number. Shows the working method. (4 marks)
- e) Based on Figure 1, find the Boolean expression for output Y. (3 marks)

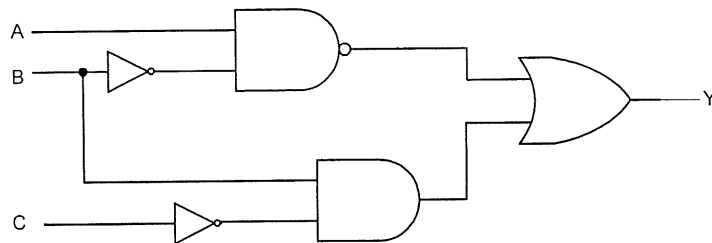
**Figure 1**

QUESTION 2

a) Answer the following questions:

- i. Draw the logic symbol for AND gate. (1 mark)
- ii. Produce the truth table for AND gate. (2 marks)

b) For the Boolean expression below.

$$X(D, E, F, G) = DF + \bar{D}EFG + D\bar{E}F + \bar{E}FG$$

- i. Determine the standard sum-of-products (SOP) expression for output X. (4 marks)
- ii. Determine the simplified output expression X using K-Map. (5 marks)
- iii. Draw the logic circuit for the simplified Boolean expression obtained in 2b(ii). (3 marks)

c) Refer to the full adder shown in Figure 2.

- i. Develop a 4-bit adder using the full adder. (4 marks)
- ii. Determine the logic state of each input and output if X=11012 and Y=11102. (4 marks)

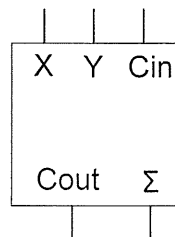

Figure 2

d) Develop the Boolean expression of $F(A, B, C) = \sum m(0,1,2,5,7)$ using:

- i. 8 to 1 multiplexer. (3 marks)
- ii. 4 to 1 multiplexer. (10 marks)

QUESTION 3

- a) Refer to Figure 3. Produce the output timing diagram, Z in Figure 4 with A and B as the input signal. (Answer this question in the given answer booklet)

(4 marks)

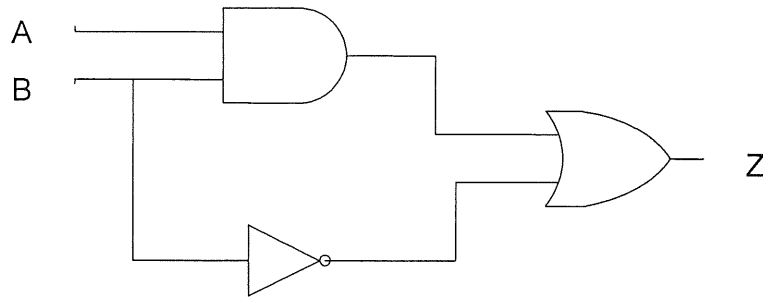
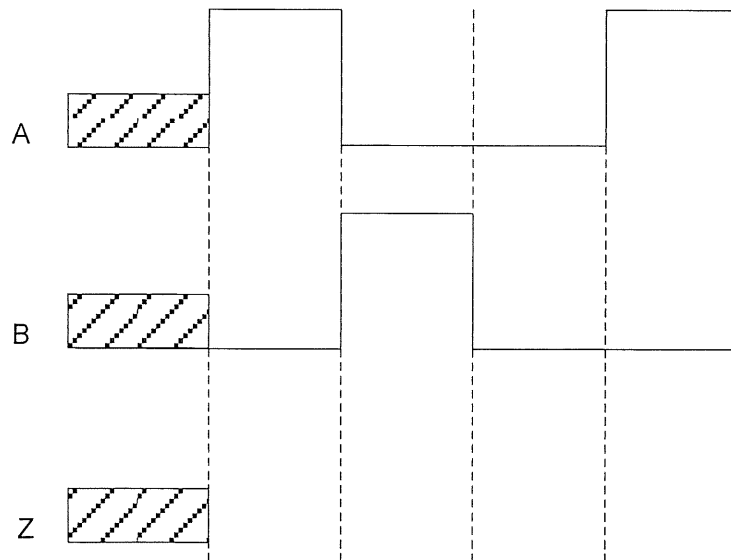
**Figure 3****Figure 4**

- b) Refer to Figure 5. Produce the output waveforms in relation to the clock for Q_A , Q_B , and Q_C in Figure 6 assuming the initial output is 0. (9 marks)

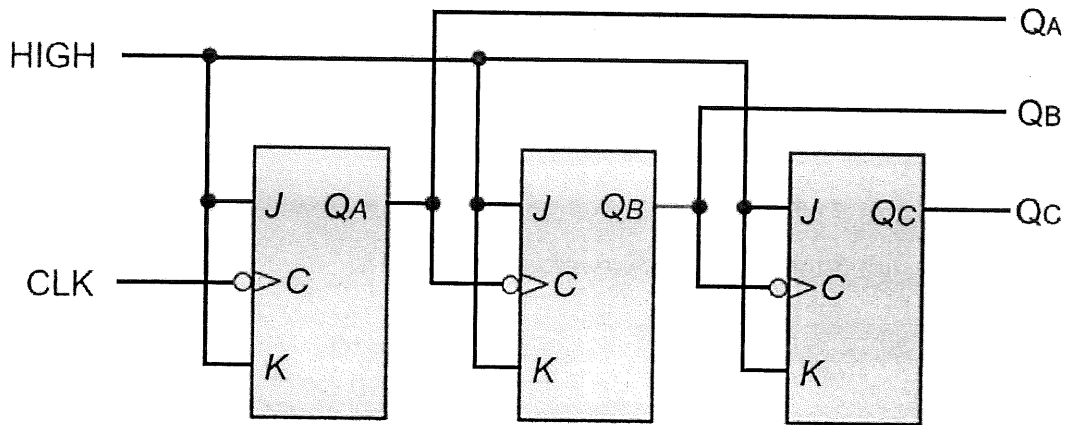

Figure 5

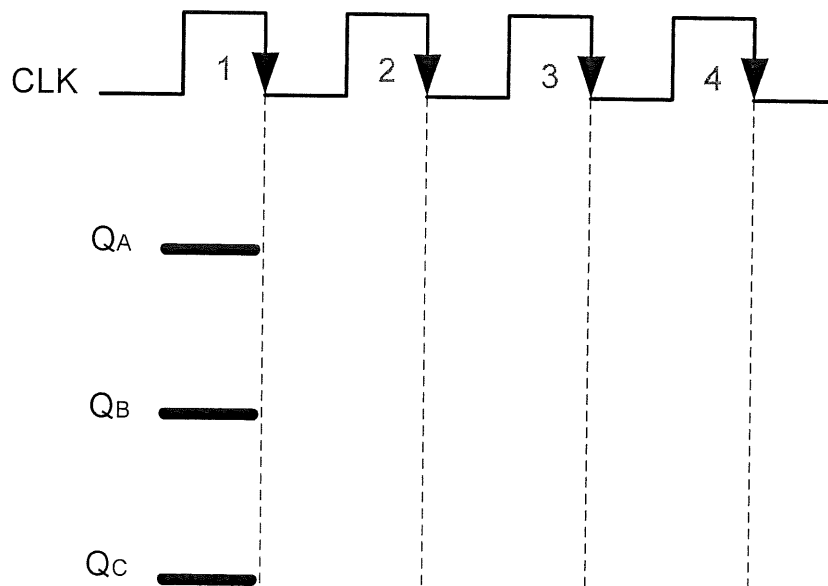
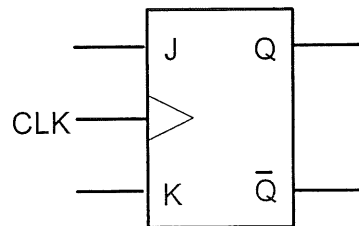
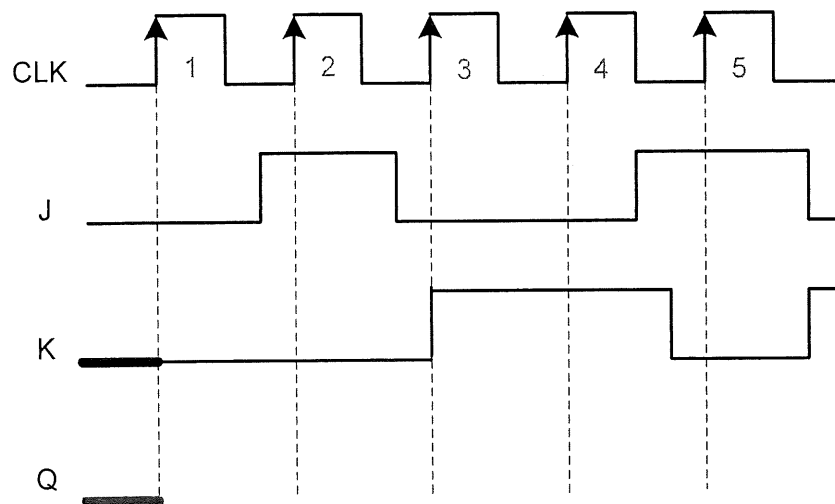

Figure 6

QUESTION 4

- a) List **THREE (3)** advantages of digital system. (3 marks)
- b) Develop 4-bit serial in serial out (SISO) shift register using D flip flop. (5 marks)
- c) List **TWO (2)** examples of sequential circuit. (2 marks)
- d) Figure 7 shows a logic symbol for JK Flip Flop. Produce the timing diagram in Figure 8 for the output waveform of signal Q. (5 marks)

**Figure 7****Figure 8**

- e) A synchronous counter with a counting sequence as shown in Figure 9 is designed by using JK flip-flops. Assume all unused states are forced to don't care condition.
- Complete the state table in Table 1. (5 marks)
 - Determine the simplified Boolean equation for J_A , K_A , J_B , K_B , J_C and K_C by using K-map. (6 marks)
 - Draw logic circuit based on the simplified Boolean expression obtained in question 4e(ii) using positive edge triggered JK flip-flop circuit with active high clock and other suitable logic gates. (4 marks)

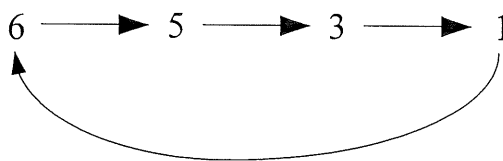

Figure 9

Table 1

PRESENT STATE			NEXT STATE			J_A	K_A	J_B	K_B	J_C	K_C
A	B	C	A'	B'	C'						
0	0	0									
0	0	1									
0	1	0									
0	1	1									
1	0	0									
1	0	1									
1	1	0									
1	1	1									

-----End of Question-----

APPENDIX 1

Table 1: Rules of Boolean Algebra

1. $A + 0 = A$	7. $A \cdot A = A$
2. $A + 1 = 1$	8. $A \cdot \bar{A} = 0$
3. $A \cdot 0 = 0$	9. $\bar{\bar{A}} = A$
4. $A \cdot 1 = A$	10. $A + AB = A$
5. $A + A = A$	11. $A + \bar{A}B = A + B$
6. $A + \bar{A} = 1$	12. $(A + B)(A + C) = A + BC$

Table 2: Excitation Table

Flip-Flop Name	Characteristic Table	Characteristic Equation	Excitation Table																																			
SR	<table border="1"> <thead> <tr> <th>S</th> <th>R</th> <th>Q_{n+1}</th> </tr> </thead> <tbody> <tr> <td>0</td> <td>0</td> <td>Q</td> </tr> <tr> <td>0</td> <td>1</td> <td>0</td> </tr> <tr> <td>1</td> <td>0</td> <td>1</td> </tr> <tr> <td>1</td> <td>1</td> <td>Invalid</td> </tr> </tbody> </table>	S	R	Q_{n+1}	0	0	Q	0	1	0	1	0	1	1	1	Invalid	$Q_{n+1} = S + \bar{R}Q$	<table border="1"> <thead> <tr> <th>Q_n</th> <th>Q_{n+1}</th> <th>S</th> <th>R</th> </tr> </thead> <tbody> <tr> <td>0</td> <td>0</td> <td>0</td> <td>X</td> </tr> <tr> <td>0</td> <td>1</td> <td>1</td> <td>0</td> </tr> <tr> <td>1</td> <td>0</td> <td>0</td> <td>1</td> </tr> <tr> <td>1</td> <td>1</td> <td>X</td> <td>0</td> </tr> </tbody> </table>	Q_n	Q_{n+1}	S	R	0	0	0	X	0	1	1	0	1	0	0	1	1	1	X	0
S	R	Q_{n+1}																																				
0	0	Q																																				
0	1	0																																				
1	0	1																																				
1	1	Invalid																																				
Q_n	Q_{n+1}	S	R																																			
0	0	0	X																																			
0	1	1	0																																			
1	0	0	1																																			
1	1	X	0																																			
JK	<table border="1"> <thead> <tr> <th>J</th> <th>K</th> <th>Q_{n+1}</th> </tr> </thead> <tbody> <tr> <td>0</td> <td>0</td> <td>Q</td> </tr> <tr> <td>0</td> <td>1</td> <td>0</td> </tr> <tr> <td>1</td> <td>0</td> <td>1</td> </tr> <tr> <td>1</td> <td>1</td> <td>\bar{Q}</td> </tr> </tbody> </table>	J	K	Q_{n+1}	0	0	Q	0	1	0	1	0	1	1	1	\bar{Q}	$Q_{n+1} = J\bar{Q} + \bar{K}Q$	<table border="1"> <thead> <tr> <th>Q_n</th> <th>Q_{n+1}</th> <th>J</th> <th>K</th> </tr> </thead> <tbody> <tr> <td>0</td> <td>0</td> <td>0</td> <td>X</td> </tr> <tr> <td>0</td> <td>1</td> <td>1</td> <td>X</td> </tr> <tr> <td>1</td> <td>0</td> <td>X</td> <td>1</td> </tr> <tr> <td>1</td> <td>1</td> <td>X</td> <td>0</td> </tr> </tbody> </table>	Q_n	Q_{n+1}	J	K	0	0	0	X	0	1	1	X	1	0	X	1	1	1	X	0
J	K	Q_{n+1}																																				
0	0	Q																																				
0	1	0																																				
1	0	1																																				
1	1	\bar{Q}																																				
Q_n	Q_{n+1}	J	K																																			
0	0	0	X																																			
0	1	1	X																																			
1	0	X	1																																			
1	1	X	0																																			
D	<table border="1"> <thead> <tr> <th>D</th> <th>Q_{n+1}</th> </tr> </thead> <tbody> <tr> <td>0</td> <td>0</td> </tr> <tr> <td>1</td> <td>1</td> </tr> </tbody> </table>	D	Q_{n+1}	0	0	1	1	$Q_{n+1} = D$	<table border="1"> <thead> <tr> <th>Q_n</th> <th>Q_{n+1}</th> <th>D</th> </tr> </thead> <tbody> <tr> <td>0</td> <td>0</td> <td>0</td> </tr> <tr> <td>0</td> <td>1</td> <td>1</td> </tr> <tr> <td>1</td> <td>0</td> <td>0</td> </tr> <tr> <td>1</td> <td>1</td> <td>1</td> </tr> </tbody> </table>	Q_n	Q_{n+1}	D	0	0	0	0	1	1	1	0	0	1	1	1														
D	Q_{n+1}																																					
0	0																																					
1	1																																					
Q_n	Q_{n+1}	D																																				
0	0	0																																				
0	1	1																																				
1	0	0																																				
1	1	1																																				
T	<table border="1"> <thead> <tr> <th>T</th> <th>Q_{n+1}</th> </tr> </thead> <tbody> <tr> <td>0</td> <td>Q</td> </tr> <tr> <td>1</td> <td>\bar{Q}</td> </tr> </tbody> </table>	T	Q_{n+1}	0	Q	1	\bar{Q}	$Q_{n+1} = T\bar{Q} + \bar{T}Q$	<table border="1"> <thead> <tr> <th>Q_n</th> <th>Q_{n+1}</th> <th>T</th> </tr> </thead> <tbody> <tr> <td>0</td> <td>0</td> <td>0</td> </tr> <tr> <td>0</td> <td>1</td> <td>1</td> </tr> <tr> <td>1</td> <td>0</td> <td>1</td> </tr> <tr> <td>1</td> <td>1</td> <td>0</td> </tr> </tbody> </table>	Q_n	Q_{n+1}	T	0	0	0	0	1	1	1	0	1	1	1	0														
T	Q_{n+1}																																					
0	Q																																					
1	\bar{Q}																																					
Q_n	Q_{n+1}	T																																				
0	0	0																																				
0	1	1																																				
1	0	1																																				
1	1	0																																				